

Orbital welding (Prefabrication)

AXXAIR
INNOVATIVE ORBITAL SOLUTIONS

Orbital welding involves rotating a Tungsten electrode around a tube to weld it to other tubes or accessories.

Our welding range incorporates a unique and atypical orbital welding machine for so-called "prefab" because it cannot be brought to the tube, it is the tube that is brought to the machine.

It is an axial loading machine which involves being able to pull out the tube as well as the welded accessory.



These machines that use standard cutting and bevelling frames have the advantage of being very robust and easy to use.

In fact, the SX range is mainly intended for workshop or building site prefabrication use. These machines are also used to carry out repeatable production welding on suitable elements.

Our machines can all be equipped with either an air-cooled torch or a water-cooled torch, with or without filler metal.

FLEXIBILITY, PRODUCTIVITY

Welding with a water or air cooled torch with or without filler metal. It allows production of medium to large series of welding sub-assemblies. The diameter range of each machine is very wide and does not require specific jaws.

QUALITY AND REPEATABILITY

TIG welding without tube distortion (multi-contact concentric clamping) ideal for thin walled stainless steel tubes. Mechanical tracking and axial adjustment optimize the quality of your welds.

EASY TO USE

Robust and intuitive, it is adapted to any operator profile.



Please do not hesitate to contact us for all enquiries relating to orbital welding technology.

We will be glad to share our know-how with you and to devise a solution that best meets your needs!



Join **experience**



SX122 - 172 - 222 - 322



No tube deformation

Concentric clamping



Basic and extra stainless steel jaws: no pollution of stainless steel tubes

Air Cooled or Water Cooled

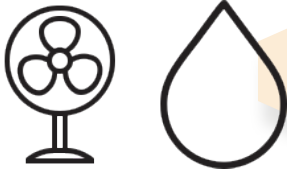



Rotating

Connect to the SAXX range welding power sources

Accurate positioning

Axial adjustment of the electrode position: facilitates location of the parts to be welded

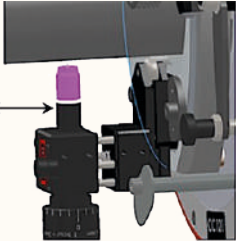
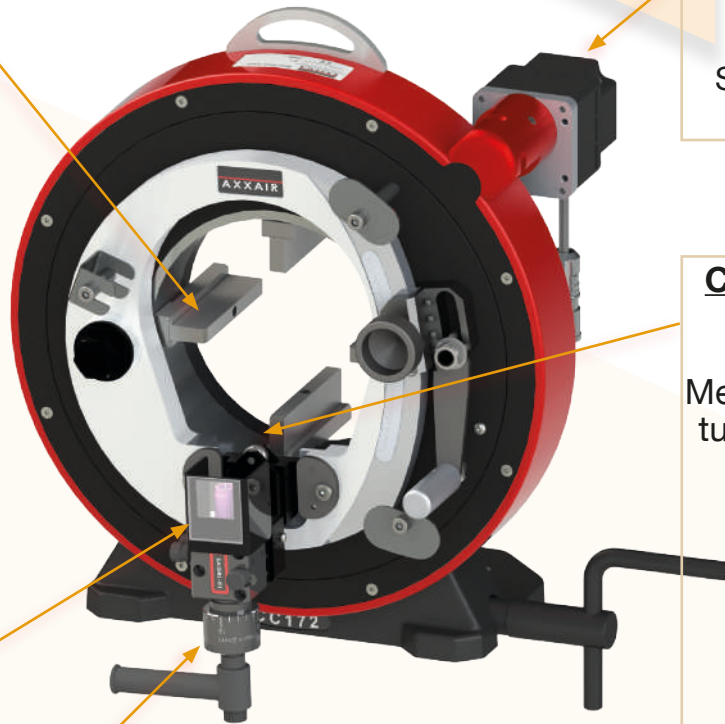
Adjustment of the tube's axial position +/- 5 mm

Constant distance: electrode-tube

Mechanical tracking of tube ovalization from the outside.



Micrometric adjustment of the height of the arc

Accuracy of adjustment without specific tooling



Easy handling and transportation



Compatible with the SAXX power sources



Opening capacity	
122	ø12 - ø119 mm 0.25" - 4.5"
172	ø16 - ø173 mm 0.625" - 6.625"
222	55 - ø228 mm 2.375" - 8.625"
322	ø141 mm - ø328 mm 5.563" - 12.750"



SX122 - 172 - 222 - 322



Technical characteristics:

Machines for TIG orbital prefab welding.



Choice of: AIR cooling or WATER cooling

For optimum use, the ambient temperature must be between 0 °C and + 40 °C.

Compatible with AXXAIR's SAXX orbital power sources that have an automatic parameter calculation mode.

The power source will offer you parameters adapted to the characteristics of the tubes / accessories to be welded.

The machine can be supplemented by a wire feed system. For details, please refer to accessories.

For welding with an AVC / OSC system please refer to the catalogue for thick walled tubes.

Model	100% Duty cycle
SX-xx2-E (WATER)	200 A
SX-xx2-A (AIR)	100 A

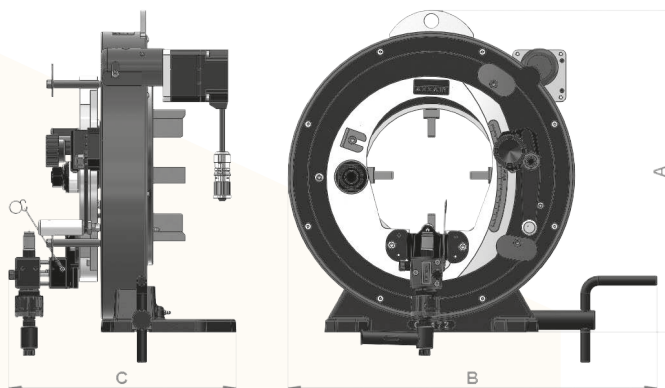

	Product Code	Machine's jaw opening capacity in mm		Net weight	Dimensions (AxBxC in mm)
		With basic jaws	With extra jaws (included)		
Cooling AIR	SX122-A	Ø29 - Ø119	Ø12 - Ø99	45 kg	446 x 541 x 350
	SX172-A	Ø74 - Ø173	Ø16 - Ø116	52 kg	493 x 566 x 350
	SX222-A	Ø128 - Ø228	Ø55 - Ø155	60 kg	548 x 594 x 350
	SX322-A	Ø230 - Ø328	Ø141 - Ø239	73 kg	649 x 644 x 350
Cooling WATER	SX122-E	Ø29 - Ø119	Ø12 - Ø99	45 kg	446 x 541 x 350
	SX172-E	Ø74 - Ø173	Ø16 - Ø116	52 kg	493 x 566 x 350
	SX222-E	Ø128 - Ø228	Ø55 - Ø155	60 kg	548 x 594 x 350
	SX322-E	Ø230 - Ø328	Ø141 - Ø239	73 kg	649 x 644 x 350

