

PIPE BEVELING MACHINE

Pipe beveling machines for weld edge prep

- High productivity
- High quality weld prep
- Accurate repetitive work
- Powerfull and durable
- Fast setup
- Less noise, dust and sparks
- Ergonomic

Video of application



MF3iw



Low weight



Perfect tooling



Strong motor



Long lifetime

TECHNICAL DATA

of pipe beveling machine MF3iw ID mount

Field of applications



The pipe beveling machine is used for weld prep of tube and pipe end in pipe welding applications. Especially for heavy wall pipes the machining is fast and accurate. Pipe beveling and facing can be done in one operation with special tool holders. Operated by one worker the pipe beveling machine can be used in the workshop and on site with low weight due to aluminum construction. High speed beveling and facing with special tool bits provides economical manufacturing of pipes, tubes and headers.





Specifications

Specifications MF3iw			Pneumatic Motor		
Clamping range ID-ID	25 - 96 mm	0,984 - 3,779"	Power	740 W	1,0 HP
Working range ID-OD	25 - 114 mm	0,984 - 4,488"	Air pressure	6 bar(g)	87 psi
Max. wall-thickness	15 mm	0,590"	Air consumption	0,96 m ³ /min	33,9 cfm
Feed	20 mm	0,787"	Air hose connection	1/4"	1/4"
Weight with electric motor	7,0 kg	15,4 lbs	Features	speed control	
Weight with pneumatic motor	5,8 kg	12,8 lbs	Electric Motor		
Weld prep	facing, V-prep, J-prep, counter boring		Power consumption	1.500 W (110V/230V)	2,0 HP
Materials	steel, stainless steel, duplex, high alloyed				
Tooling	tool bits, TiN inserts, custom bits		Features	restart and overload protection, speed adjustment, torque control	
Machine body	Aluminium alloy				

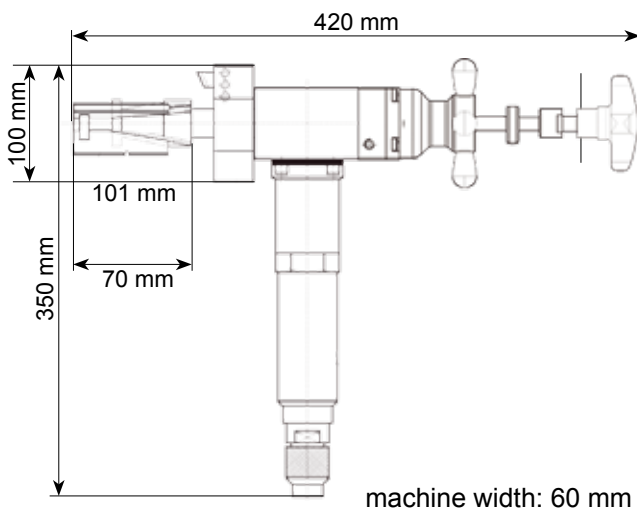
Dimensions



Options

- 
 Enlargement XL to cover range ID 16 - 96 mm (0,629 - 3,779 inch) with center shaft, tool holder and clamping set (only with push lever)
- 
 Push lever for fast feeding
- 
 Tooling for heat exchanger repair to remove the weld seam in the tube sheet

